

# LLRV 51 M 500 P3K-IBS

## Laser Line Retroreflective Sensor

- Fan-shaped laser beam with auto-collimation principle
- Detection of smallest parts within the entire active zone
- Red light laser
- 4-turn potentiometer
- Robust metal casing



### Safety instructions

Inproper use may result in hazardous radiation exposure. Pay attention to accident prevention rules and laser class. The instruments are not to be used for safety applications, in particular applications in which safety of persons depends on proper operation of the instruments. These instruments shall exclusively be used by qualified personnel.

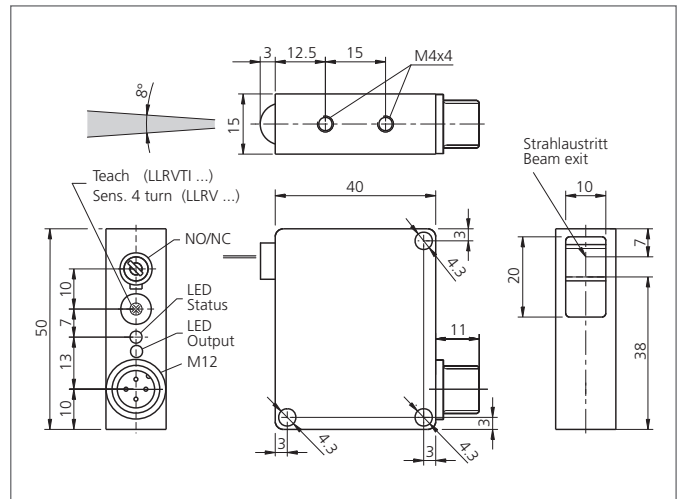

TECHNICAL INFORMATION (typ.)		+20°C, 24V DC
Operating principle		Retroreflective sensor
Evaluation		digital
Size		50 x 40 x 15 mm (Dimensions)
Design		cuboid design
Emitted light		Red light laser, 670 nm, clocked
Laser class		1 (IEC 60825-1)
Operating distance		50 ... 500 mm
Service voltage		10 ... 35 V DC
Internal power consumption		< 30 mA
Resolution		25 ... 100 % covering of laser line
Sensitivity adjustment		potentiometer
Switching output		pnp, 200 mA, NO/NC, switchable
Switching frequency		750 Hz
Ambient temperature		+5 ... +50 °C
Ambient light immunity		15 kLx
Insulation voltage endurance		500 V
Protection class		IP 67
Protection degree		III, operation on protective low voltage
Casing material		Die-cast zinc black lacquered finish
Material		polymethyl methacrylate (Window)
Connection		Connector, M12, 3-poled
Connecting cable		VK ...